

Informacijski list proizvoda (HR)

Product information (ENG)

VIVAX



100 W
JAČINA MOTORA



281 m³/h
PROTOK ZRAKA



ALUMINIJSKI
FILTER

Kuhinjska napa CHO-60CHA100T X

Štedite energiju uz našu napu visoke energetske klase! Snage motora od 100 W uspješno će izvući sav neugodan miris i masnoću iz vaše kuhinje. A ukoliko vas uhvati želja za kasnonoćnim obrokom, ne brinite – snažno LED svjetlo jednako će raspršiti svjetlost duž radne ploče. Aluminijsko kućište lako se čisti i održava kao i filteri masnoće, koji su perivi u perilici posuđa.

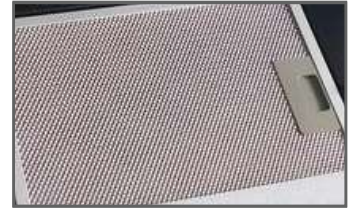

Aluminijski filter



LED Rasvjeta

Snaga motora
100 W

Brzine motora
3

Protok zraka (ERP)
281 m³/h

Napajanje / Ukupna snaga
102 W

Minimalna / Maksimalna razina buke
62 dB / 68 dB

Klasa energetske učinkovitosti
D

Učinkovitost filtriranja masnoće
E

Razred učinkovitosti osvjetljenja
A

Tip svjetla
2 x 1W LED Ø 35.8mm, 208 lux

Vanjski izgled / Kontrole
Nehradajući čelik / Kromirane Tipke

Tip filtera
2 x Aluminijski filter u 3 slojeva

Ugljeni filter za unutarnju cirkulaciju zraka
CP350 (naručuje se posebno)

Promjer odvodnog crijeva / Mjesto priključka
150 mm / Gornja strana

Pribor u kompletu
Savijljivo crijevo Ø 150 x 1500 mm; Nosači i pribor za montažu; Energetska naljepnica; Upute za uporabu i montažu

Bruto / Neto težina
6,1 kg / 5,0 kg

Dimenzija paketa / Dimenzija uređaja
650 x 538 x 240 mm / 596 x 453 x 657-871 mm

EAN Kod
3856005186792

SAP Kod
1256541

VIVAX



100 W
JAČINA MOTORA



281 m³/h
PROTOK ZRAKA



ALUMINIJSKI
FILTER

Kuhinjska napa CHO-60CHA100T X

Štedite energiju uz našu napu visoke energetske klase! Snage motora od 100 W uspješno će izvući sav neugodan miris i masnoću iz vaše kuhinje. A ukoliko vas uhvati želja za kasnonoćnim obrokom, ne brinite – snažno LED svjetlo jednako će raspršiti svjetlost duž radne ploče. Aluminijsko kućište lako se čisti i održava kao i filteri masnoće, koji su perivi u perilici posuđa.



DIMENZIJE PROIZVODA

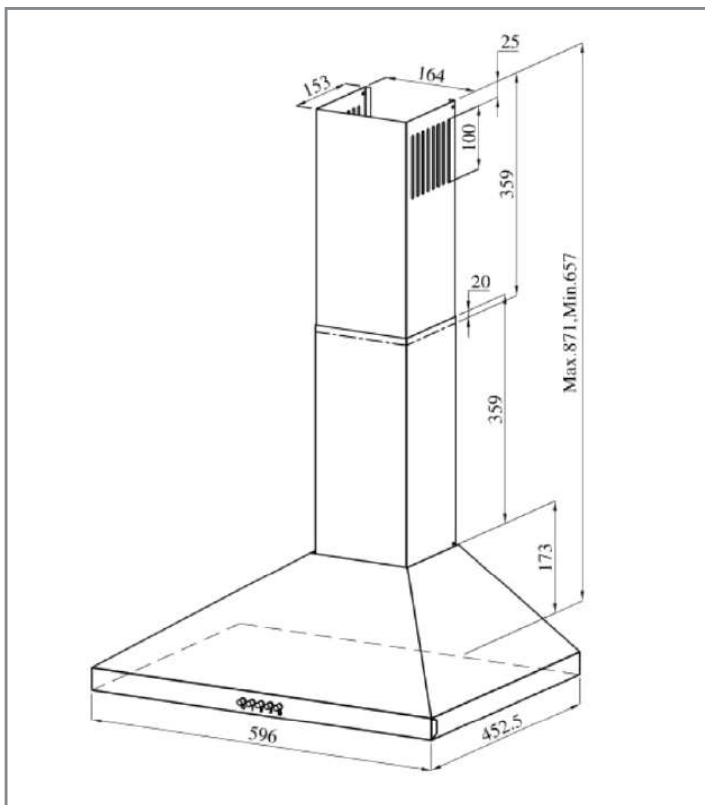

ENERGETSKA NALJEPNICA

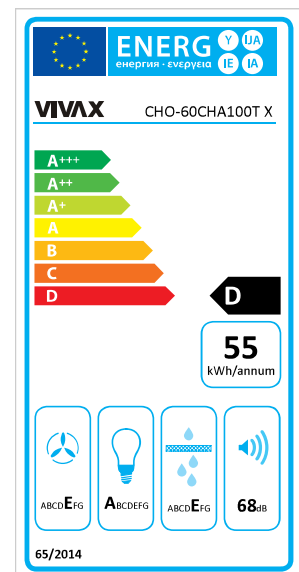

ZAMJENA SVJETLA

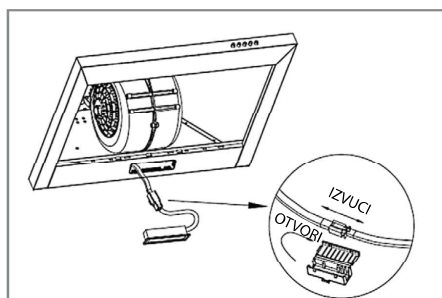
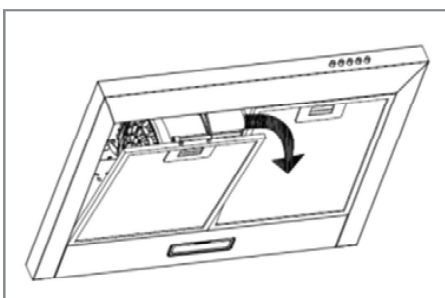

UPOZORENJE:
Zamjenu osvjjetljenja mora izvesti ovlaštenu osobu ili slična kvalificirana osoba kako bi se izbjegla opasnost od električnog udara.

VIVAX

100 W
MOTOR POWER



283 m³/h
AIR FLOW

ALUMINUM
FILTER

Kitchen Hood

CHA-60CHA100T X

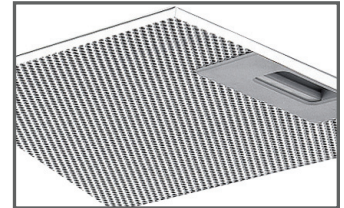
Save energy with our high efficiency energy kitchen hood! The power of the 70 W motor will successfully remove all unpleasant odors and grease from your kitchen. And if you get a late-night food cravings, don't worry - a strong LED light will scatter light evenly along the worktop. The aluminum housing is easy to clean and maintain as are the grease filters, which are dishwasher safe.



Aluminum filter

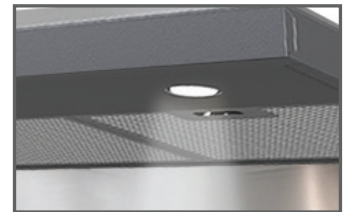

LED lighting

Motor Power
100 W

Number of engine speeds
3

Air Flow (ErP)
283 m³/h

Power Supply / Power
100W

Min. / Max. noise level
62 dB / 68 dB

Energy efficiency class
D

Grease filtering efficiency
E

Lighting efficiency class
A

Type of light source
LED 2x 1W 35.8mm, 208 lux

Exterior / Controls
Stainless steel / Chrome Buttons

Filter Type
Aluminum filter in 3 layers

Carbon Filter for indoor air circulation
CH~CP100T (purchased separately)

Exhaust hose diameter / Connection location
150 mm / Upper Side

Installation Accessories
Bracket and mounting accessories; Energy label; Instructions for use and installation

Gross / Net Weight
6,1 kg / 5.0 kg

Package Dimension / Appliance Dimension
650 x 538 x 240 mm / 596 x 453 x 657-871 mm

EAN Code
3856005186792

SAP Code
1256541

VIVAX



100 W
MOTOR POWER



283 m³/h
AIR FLOW



ALUMINUM
FILTER

Kitchen Hood CHA-60CHA100T X

Save energy with our high efficiency energy kitchen hood! The power of the 70 W motor will successfully remove all unpleasant odors and grease from your kitchen. And if you get a late-night food cravings, don't worry - a strong LED light will scatter light evenly along the worktop. The aluminum housing is easy to clean and maintain as are the grease filters, which are dishwasher safe.

APPLIANCE DIMENSIONS

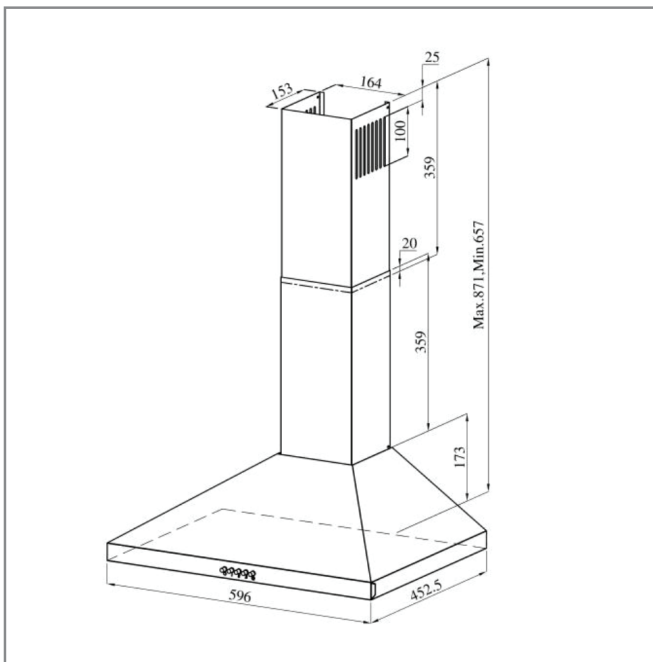

LIGHT REPLACEMENT

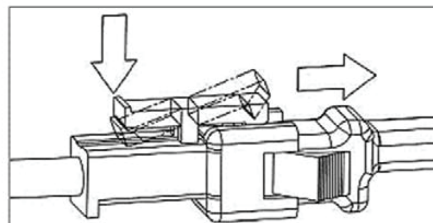
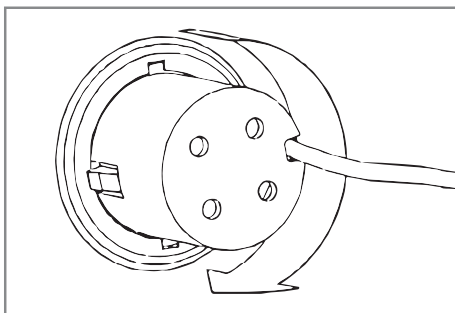

WARNING:
Lighting replacement must be performed by an authorized service center or similar qualified person to avoid the risk of electric shock.

ENERGY LABEL

